



Nissan Patrol

Y62





Installation Instructions



Nissan Patrol Y62 Emuwing Installation Instructions

Due to the intrusion of the hinge this product is not suitable for vehicles that passengers in the seats adjacent to the Emuwing. The Emuwing is designed as an addition to a storage system and should be removed if the seats adjacent to the Emuwing are ever reinstated.

Parts List

| | | |
|--|--|--|
|  <p>Frame x 1 per side</p> |  <p>Wing panel x 1 per side</p> |  <p>Glue & Nozzle x 1 per kit</p> |
|  <p>Support Brackets x 2 per side</p> |  <p>Hinge & Faceplate - Front & Rear per side (Pre-assembled)</p> |  <p>Wing Panel Rubber x 1 per side</p> |
|  <p>Gas Strut x 2 per side</p> |  <p>Plastic Grommets x 2 per side</p> |  <p>Panel buttons x4 per side</p> |
|  <p>M4 Nyloc Nut x 8 per side</p> |  <p>M4 Washer x 8 per side</p> |  <p>M4 Hex bolts x 8 per side</p> |
|  <p>Chalk marker x 1 per kit</p> |  <p>Keyring x 1 Keys x 4</p> |  <p>Instructions x 1</p> |
|  <p>Flyer x 1</p> | <p>Tool required:</p> <ul style="list-style-type: none"> - Allen Keys (2.5mm & 4mm) - Small flathead screwdriver - Phillips screwdriver - Clamps - Spanners (7mm, 10mm & 27mm) - Caulking/Glue gun - Cleaning fluid (to clean surface) - Rags | |

Nissan Patrol Y62 Emuwing Installation Instructions

Due to the intrusion of the hinge this product is not suitable for vehicles that passengers in the seats adjacent to the Emuwing. The Emuwing is designed as an addition to a storage system and should be removed if the seats adjacent to the Emuwing are ever reinstated.

Contents

| | |
|---|----------|
| Parts List..... | 1 |
| 1: Remove the existing rear window and mark the interior trim for cutting. | 3 |
| - Remove interior trim, glass and rubber..... | 3 |
| - Marking interior trim for cutting. | 3 |
| 2: Installing the frame. | 4 |
| - Positioning the frame (No Glue yet). | 4 |
| - Gluing the frame into place. | 5 |
| - Cutting interior trims. | 6 |
| 2: Attaching the door panel. | 6 |
| - Tighten the support brackets..... | 6 |
| Figure 5 | 6 |
| - Attach the hinges. | 6 |
| - Placing the door panel. | 7 |
| - Securing the door panel..... | 7 |
| - Attach the gas struts..... | 7 |
| 3: Adjusting the door panel depth and fitting the weather-strip. | 7 |
| - Adjustments – left/right and up and down. | 7 |
| - Applying the weather-strip. | 8 |
| - Adjustments – Depth. | 8 |
| - Thread locking compound – handle/cam screws. | 8 |
| 5. Glass supplement..... | 9 |
| | 9 |

The following instructions detail the installation of your new EmuWing kit; allow a total of three to four hours fitting time for each panel excluding curing time. Read the instructions thoroughly before starting.

Allow any additional time that may be required for rust and paint repairs. We have installations on our YouTube channel which may be worth looking at before beginning.

Note: The radio antenna is embedded in these windows and will need to be replaced.

Nissan Patrol Y62 Emuwing Installation Instructions

Due to the intrusion of the hinge this product is not suitable for vehicles that passengers in the seats adjacent to the Emuwing. The Emuwing is designed as an addition to a storage system and should be removed if the seats adjacent to the Emuwing are ever reinstated.

1: Remove the existing rear window and mark the interior trim for cutting.

- Remove interior trim, glass and rubber.

The interior trim on the Y62 is in multiple sections and simply clips into place, after removing any handles and seatbelt mounts carefully pull the panels off being careful not to lose or break any of the plastic clips, they may become brittle with age. We find starting from the bottom by removing the panel over the rear wheel arch is the easiest way, work your way upwards until all trims surrounding the window are removed.

The upper interior trim is held in place with plastic connectors that are designed to allow the airbag to deploy, these are difficult to remove and may need to be cut.

We recommend contacting a glazier to have the window removed as the panel is glued in place, however if you do decide to cut this out something worth investing in for this job would be a windscreen removal tool. Beware as there are plastic clips within the existing glue that are difficult to cut through.

Expect some paint damage due to the shape of the panel around the rear most sides behind the window, ensure you have a touch up pen handy.

After removing the rear window, wash off any dirt and carefully remove as much residual glue from around the seam as you can. The previous glue does not have to be completely removed but you should ensure the Emuwing frame can be mounted as close to the car body as possible by removing any excess glue.

- Marking interior trim for cutting.

Once the windows have been removed, reinstall all the interior trims temporarily, once they are all mounted in the original position, they will overhang the outside of the car. The frame of the EmuWing will sit flush against the body so any excess material needs to be marked for removal.

Before removing the interior trim, you can also mark the top support bracket as this requires around 5mm of additional material to be removed. Hold the frame against the car and mark the position of the top supports of the frame onto the plastic interior trim. (Figure 1). Once the trim has been marked up it can be removed and cut.

We take out more than 5mm around the nuts and bolts as this trim will interfere with them – see **Figure 2** below.

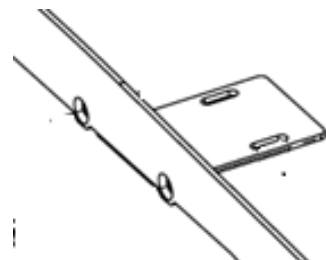

Support bracket on frame
Figure 1

Nissan Patrol Y62 Emuwing Installation Instructions

Due to the intrusion of the hinge this product is not suitable for vehicles that passengers in the seats adjacent to the Emuwing. The Emuwing is designed as an addition to a storage system and should be removed if the seats adjacent to the Emuwing are ever reinstated.

2: Installing the frame.

- Positioning the frame (No Glue yet).

The frame is supplied assembled and should be fitted to the car as supplied with the support brackets in place (**Figure 2**) – use some tape to hold them in place whilst positioning the frame.

Firstly, the top interior panel must be trimmed and refitted prior to installation of the frame. This will be next to impossible to install once the frame has been glued in place.

The side and bottom trims around the window should be removed prior to installation of the frame so clamps can be attached easily.

The frame should be positioned as high as possible, whilst ensuring the front of the frame is in line with the rear door – see **figure 3**



Figure 3



Figure 2.

Refit the top interior trim only and retest to ensure the frame sits flush against the body of the vehicle before applying any glue, if further trimming is required ensure this is done before applying any glue. We reiterate the top panel cannot be re-fitted once the frame is glued in place. At this point place a clamp on each corner of the frame, the frame will easily mould to the car. Apply some masking tape around the frame, this will help with glue clean up later in the process.

Nissan Patrol Y62 Emuwing Installation Instructions

Due to the intrusion of the hinge this product is not suitable for vehicles that passengers in the seats adjacent to the Emuwing. The Emuwing is designed as an addition to a storage system and should be removed if the seats adjacent to the Emuwing are ever reinstated.

- Gluing the frame into place.

Remove the frame and clean the back thoroughly and around the rear window seam ensuring no residuals are left on either surface. Wearing gloves will ensure no grease or oils from your hands contaminate the surfaces.

Apply an even consistent bead of Sikaflex around the inside edge of the window seal on the car – approximately 6/7mm wide, increasing the bead slightly to 8/9mm around the corners.

Make you're your bead also goes around the window locating holes.

There is plenty of glue in your kit for a practice run before putting anything on the car.

Make sure there are no gaps in the bead, and it is consistent around the window.

Our first bead is done around the window on top of the original glue, we then do an additional bead around the front edges to ensure no moisture can get behind the frame.

Make sure your clamps are to hand before placing the frame.

Place the frame into position and place clamps firstly onto each corner, then along the bottom edges and sides if required.

We recommend looking closely to ensure no light can be seen between the frame and car. Use more clamps if required.

Place a clamp onto the frame on the front edge, where the frame meets the rear door - at the top and bottom ensuring the frame is pulled tightly to the form of the vehicle.

The support brackets can now be tightened just enough to put pressure on the glue on the top edge and help to support the frame in position, tighten until the glue just begins to squeeze without distorting the frame. These can be further tightened once the glue has cured.

Once the glue is applied and the frame is in place, leave to dry for at least 24 hours.

Whilst the glue is wet and the frame is clamped, carefully clean up any excess glue from around the frame.

Use an old rag to push the excess glue onto the masking tape, once all the glue has been pushed back – remove the masking tape carefully ensuring the glue remains on the tape and not all over you and the car.

The glue can be cleaned up using wax and grease remover whilst wet, do not leave it to dry as its much more difficult to remove without damage to the paintwork.

Do Not proceed with fitting any hardware to the frame until the glue has set and the frame is securely in place (at least 24 hours). (Figure 4)

Nissan Patrol Y62 Emuwing Installation Instructions

Due to the intrusion of the hinge this product is not suitable for vehicles that passengers in the seats adjacent to the Emuwing. The Emuwing is designed as an addition to a storage system and should be removed if the seats adjacent to the Emuwing are ever reinstated.

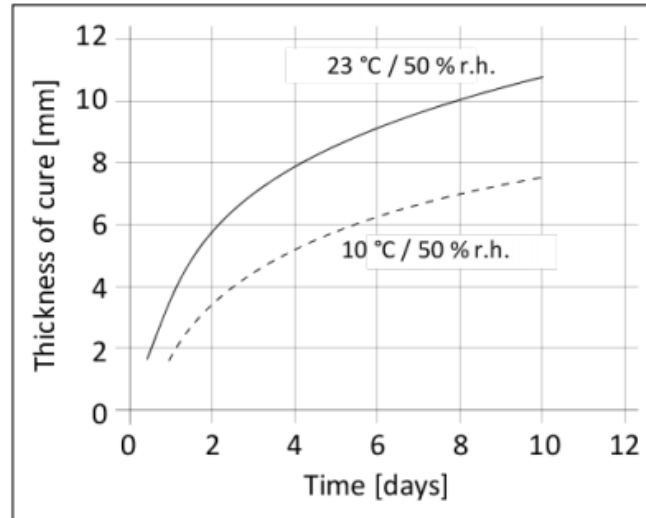

Figure 4.

- Cutting interior trims.

The interior trim can be cut in preparation for reinstallation. There is a guide on our YouTube channel worth looking up if you are not sure about these cuts. Carefully cut along the marks you made on the interior trim.

2: Attaching the door panel.

- Tighten the support brackets.

Ensure the two bolts are evenly tightened so the slots in the two brackets align and the bracket is firmly against the body.

(Figure 5)

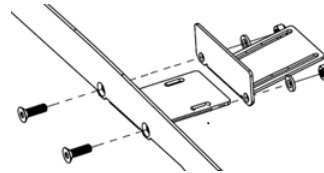

Figure 5

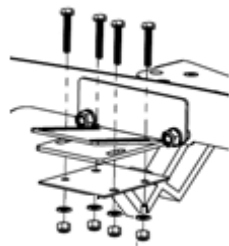

Figure 6.

- Attach the hinges.

Attach the Hinges to the frame using the supplied 4mm nuts, bolts and washers so the face plate protrudes around 8mm from the frame. The exact depth will be adjusted later. (Figure 6).

Nissan Patrol Y62 Emuwing Installation Instructions

Due to the intrusion of the hinge this product is not suitable for vehicles that passengers in the seats adjacent to the Emuwing. The Emuwing is designed as an addition to a storage system and should be removed if the seats adjacent to the Emuwing are ever reinstated.

- Placing the door panel.

Put some masking tape over any vulnerable areas of paint before putting the panel in place and place a soft rag over the lower part of the frame so it covers any paintwork that could be damaged.

When the hinges are in the closed position, place the door panel centrally. We suggest using masking tape at the top of the door panel to lift it up slightly so that the panel is aligned correctly. Closing the rear passenger doors will help.

Note: when the gas struts are attached the door panel will be pushed up as the hinges compress – try to allow for this when placing the door by positioning the panel 1 or 2 mm lower than it needs to be. (Figure 7)

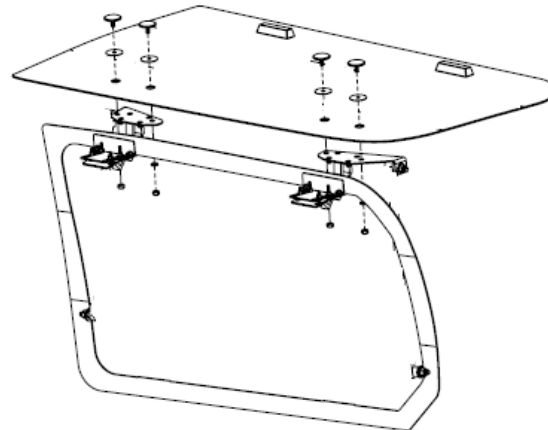

Figure 7

Close the handles so the cam latches over the frame to secure the panel in place while fixing.

- Securing the door panel.

Placing the Pan Head bolts from the outside; fit a washer and nut on the inside.

Once all four pan heads are in place and secure, check that the door does not touch the car when opening and closing. If there is any touching, adjust the door accordingly before attaching the gas struts.

- Attach the gas struts.

Once the Door panel is adjusted as much as possible open the door and check all nuts and bolts are tightened, then attach the struts (wider end to the top). Close the panel carefully, again watching if it touches the car as it closes. Once closed note any required adjustments to the door panel to align it with the car.

The depth of the door can be adjusted later, once the seal has been attached. At this stage we are only concerned with the position of the panel in relation to the car however if your panel sits out from the frame more than 8mm it may be worth adjusting this in to at least 8mm.

- Before loosening any nuts for any further adjustments, detach the gas struts first.

3: Adjusting the door panel depth and fitting the weather-strip.

- Adjustments – left/right and up and down.

The door panel can be adjusted up/down and left/right by loosening the pan heads that attach the door to the hinge. Make note of the required adjustments and mark the current position of the hinge plate on the inside of the door before removing the struts and loosening the pan heads.

Once you are happy the door panel is adjusted into position and the gas struts are reinstalled, the weather seal can be attached to the inside.

Nissan Patrol Y62 Emuwing Installation Instructions

Due to the intrusion of the hinge this product is not suitable for vehicles that passengers in the seats adjacent to the Emuwing. The Emuwing is designed as an addition to a storage system and should be removed if the seats adjacent to the Emuwing are ever reinstated.

- Applying the weather-strip.

Close the door panel and carefully mark inside the door panel around the inside edge of the frame noting the distance between the line and the edge of your frame - chalk pens are great for this. (Figure 8)



Once the door has been marked, the weather seal can be attached to the door following the marked lines so the seal will line up with the inside edge of the frame

Do not stretch the weather strip, especially around the corners – just allow it to place onto the panel. Otherwise, you may find it will shrink with heating and peel from the panel.



Figure 8

- Adjustments – Depth.

Once the weather seal has been set in place, close the door panel and check the depth to ensure it aligns with the car and compresses the rubber seal. If adjustment is required loosen the hinges from the top supports (the gas struts do not need to be removed but beware they may try to push the door outwards), apply pressure evenly to the outside of the door where the hinge meets the door until you see the rubber compress, and then re-tighten the bolts. Another pair of hands really helps here, ensure the gap is the same on both front and back hinges.

You may also need to bend the cams on the door locks to compress the bottom part of the rubber seal. To do this remove the cam by taking the screw out from the back of the door handle. Put the cam into a vice so that any bend is applied away from the square hole – do not distort or bend this part of the cam. Bend slightly and then retest until the rubber on the panel compresses equally top and bottom.

- Thread locking compound – handle/cam screws.

The small screw holding the handle and cam in place has not had thread locking compound applied to facilitate any bending required. **It is essential this is applied onto these screws to ensure you retain your handles.**

Close the Emuwing and leave the car in the sun for a few hours to activate the glue on the back of the weather seal – leave the wing closed for around 24 hours while the glue on the weather seal sets. The panel needs to get hot to the touch to activate the glue on the rubber and ensure long term adhesion. A heat gun may assist in colder weather.

If additional help is required, please feel free to give us a call on +613 8592 1926 between the hours of 10am and 4pm AEST – Monday to Friday.

Nissan Patrol Y62 Emuwing Installation Instructions

Due to the intrusion of the hinge this product is not suitable for vehicles that passengers in the seats adjacent to the Emuwing. The Emuwing is designed as an addition to a storage system and should be removed if the seats adjacent to the Emuwing are ever reinstated.

5. Glass supplement.

Please note the following:

Handles have been inserted so you can easily reassemble them after having the glass wing panels tinted. When reassembling, you must use some thread locking compound on the threads to prevent them loosening. Failure to do so may result in the loss of the entire assembly including the handle and lock, this will not be covered under warranty.

We recommend tinting the glass prior to installation, this ensures the weather strip will not deteriorate faster than usual due to UV exposure.

Instructions:

1. Remove handles
2. Tint glass wing panel to match the existing tint on your vehicle.
3. Reassemble handles using thread locking compound on all threads

Prior to installation of the Emuwing kit the handles should be reassembled into the glass panel using a thread locking compound on the large barrel nut, apply enough to ensure this barrel nut will not loosen.

Tighten the barrel nut until the rubbers are compressed ensuring a good seal.

Do not use thread locking compound on the screw holding the cam in place at this stage, this is done later in the installation process.

Contact Us

website: emuwing.com.au

phone: +61 3 9017 1614

email: info@emuwing.com.au

Find us at:



For *Distributor/Installer* enquiries, email
sales@emuwing.com.au

9/146 Northbourne Road Campbellfield Vic 3061
ABN: 84 617 251 733