

LC76 Emuwing Installation Instructions

Due to the intrusion of the hinge this product is not suitable for vehicles with passengers in the seats adjacent to the Emuwing. The Emuwing is designed as **an addition** to a storage system and should be removed if the seats adjacent to the Emuwing are ever reinstated.

Contents

1: Remove the existing rear window.....	2
Remove original window.	2
Applying the pinch weld.	2
2: Installing the frame.	2
Positioning the frame.....	2
Gluing the frame into place.	2
3: Attaching the door panel.....	3
Place and tighten the support brackets.....	3
Attach the hinges.	3
Placing the door panel.	4
Securing the door panel.....	4
Attach the gas struts.....	5
4: Adjusting the door panel depth and fitting the weather-strip.	5
Adjustments – left/right and up and down.	5
Applying the weather-strip.	5
Primer.....	5
Adjustments – Depth.	5
Thread locking compound – handle/cam screws.	6
5. Glass supplement.....	7

The following instructions detail the installation of your new EmuWing kit.

Allow a total of one to two hours fitting time for each panel, excluding curing time.

Read the instructions thoroughly before starting the installation.

Allow any additional time that may be required for rust repairs.

We have installations on our YouTube channel which you may wish to watch before commencing.

LC76 Emuwing Installation Instructions

Due to the intrusion of the hinge this product is not suitable for vehicles with passengers in the seats adjacent to the Emuwing. The Emuwing is designed as **an addition** to a storage system and should be removed if the seats adjacent to the Emuwing are ever reinstated.

1: Remove the existing rear window.

Remove original window.

Remove the trim covering the rear door pillar.

Remove the two screws retaining the hinge at the back.

There are four bolts to remove - a long 10mm socket is ideal to get the recessed front nuts. Take great care removing these nuts at the front – if the nuts are dropped, retrieval may be all but impossible and a permanent rattle may remain.

Applying the pinch weld.

After removing the rear window, wash off any dirt or residual glue from around the seam.

If there is any rust, address this now before continuing.

Apply the pinch weld supplied in the kit starting on the bottom edge, continue around the exposed seam ensuring that any interior trims and the roof lining are securely held in place.

2: Installing the frame.

Positioning the frame.

Make sure you understand the positioning of the frame before attempting to glue it into position.

This is critical so the panel aligns to the hinges later in the assembly.

The frame mounts centrally with an even gap all the way around, if you do not get this perfect you will be able to adjust the door panel later during the installation.

Prior to applying any glue place the frame in position with a clamp on each corner, now apply masking tape around the position of the frame – this will help with the clean-up of any excess glue if any does squeeze out.

Gluing the frame into place.

The surface of the pinch weld and the frame should be clean, dry and free from all traces of grease, oil and dust before applying a bead of Sikaflex around the outside of the pinch weld, (*paying particular attention*) to the corners increasing the bead enough to fill any higher spots between the body and the frame. Apply a continuous bead around 5mm thick, increasing this to 6/7mm around the corners.

Make sure there are no gaps in the bead, and it is applied evenly. Get some light clamps and place them close by, you will need them as you place the frame into position.

Remove the nuts and washers from the top of the frame before putting it in place.

Once the glue is applied and the frame is in place, apply the clamps paying particular attention to the corners and leave to dry for at least 24 hours. Using a torch check no light can be seen between the frame and the car body.

Whilst the glue is wet and the frame is clamped, carefully clean up any excess glue from around the frame. The masking tape applied earlier will help with this, once done the masking tape can be removed.

Once the glue is applied and the frame is in place, leave to dry for at **least 24 hours**.

LC76 Emuwing Installation Instructions

Due to the intrusion of the hinge this product is not suitable for vehicles with passengers in the seats adjacent to the Emuwing. The Emuwing is designed as **an addition** to a storage system and should be removed if the seats adjacent to the Emuwing are ever reinstated.

The glue can be cleaned up using wax and grease remover whilst wet, do not leave it to dry or it will be difficult to remove without damage to the paintwork.

Do Not proceed with fitting any hardware to the frame until the glue has set and the frame is securely in place (at least 24 hours). Pic 1.

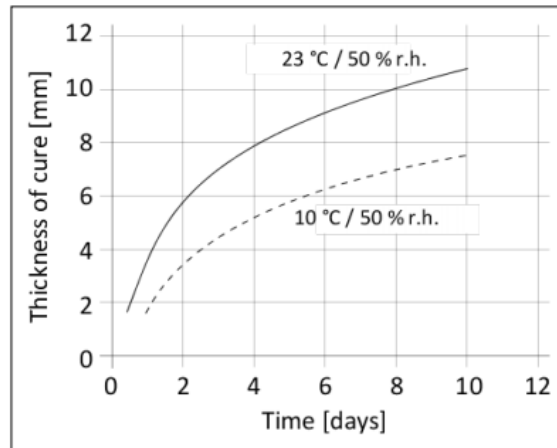

Pic 1.

3: Attaching the door panel.

Place and tighten the support brackets.
First place the foam rubber on the raised body section at the back of the window, this will prevent the panel touching the body of the vehicle.

Assemble the support brackets on top of the frame; using the previously removed nuts and bolts to clamp the frame to the body. Do not over tighten these bolts, just tighten them firmly. Pic 2.

Ensure the two bolts are evenly tightened so the slots in the two brackets align and the bracket is firmly against the body. You will need to carefully roll the foam rubber back to get the Allen key into the bolt, press firmly back in place once tight.

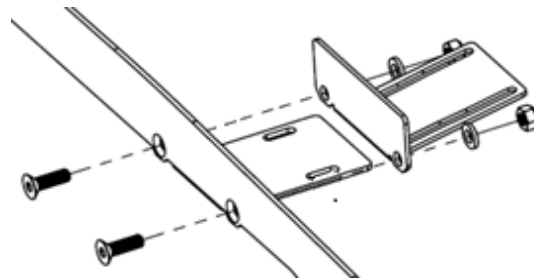

Pic 2.

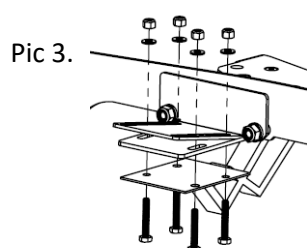

Pic 3.

Attach the hinges.

Attach the Hinges to the frame using the supplied 4mm nuts, bolts and washers so the face plate protrudes around 10mm from the frame. The exact depth will be adjusted later. Pic 3.

LC76 Emuwing Installation Instructions

Due to the intrusion of the hinge this product is not suitable for vehicles with passengers in the seats adjacent to the Emuwing. The Emuwing is designed as **an addition** to a storage system and should be removed if the seats adjacent to the Emuwing are ever reinstated.

Placing the door panel.

When the hinges are in the closed position, place the door panel centrally. We suggest using a spacer at the bottom of the door panel to lift it up slightly so that the panel is aligned correctly. Pic 4.

Note: when the gas struts are attached the door panel will be pushed up as the hinges compress – try to allow for this when placing the door by positioning the panel 1 or 2 mm lower than it needs to be.

Close the handles a little so the cam latches over the frame to secure the panel in place while fixing into position.

Within your kit is a small piece of foam rubber, this is used to protect the vehicle from any potential rubbing, this should be placed as shown here

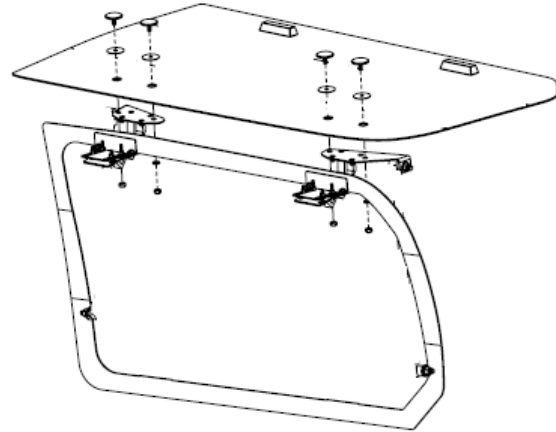

Pic 4.



Securing the door panel.

Placing the Pan Head bolts from the outside; fit a washer and nut on the inside.

Once all four pan heads are in place and secure, check that the door does not foul the car when opening and closing. If there is any fouling, adjust the door accordingly before attaching the gas struts.

Before loosening any nuts for any further adjustments, detach the gas struts first to prevent the hinges from twisting.

LC76 Emuwing Installation Instructions

Due to the intrusion of the hinge this product is not suitable for vehicles with passengers in the seats adjacent to the Emuwing. The Emuwing is designed as **an addition** to a storage system and should be removed if the seats adjacent to the Emuwing are ever reinstated.

Attach the gas struts.

Once the Door panel is adjusted as much as possible open the door and attach the struts (wider end to the top). Close the panel carefully, again watching if it touches the car as it closes. Once closed note any required adjustments to the door panel to align it with the car.

The depth of the door can be adjusted later, once the seal has been attached. At this stage we are only concerned with the position of the panel in relation to the car however if your panel sits out from the frame more than 10mm it may be worth adjusting this in to at least 10mm.

4: Adjusting the door panel depth and fitting the weather-strip.

Adjustments – left/right and up and down.

The door panel can be adjusted up/down and left/right by loosening the pan heads that attach the door to the hinge. Make note of the required adjustments and mark the current position of the hinge plate on the inside of the door before removing the struts and loosening the pan heads. Once you are happy the door panel is adjusted into position and the gas struts are reinstalled, the weather seal can be attached to the inside.

Applying the weather-strip.

Close the door panel and carefully mark inside the door panel around the inside edge of the frame noting the distance between the line and the edge of your frame.

Primer

Before attaching the weather strip use the 3M primer where you will be applying the weather strip. Apply using long strokes exactly where the weather strip will be placed



Once the door has been marked and primed, the weather seal can be attached to the door following outside of the marked lines so the seal will line up on the frame (if the seal does not correctly align, moisture and dust will find its way into the back of the vehicle).



Do not stretch the weather strip, especially around the corners – just allow it to place onto the panel. Otherwise, you may find it will shrink with heating and peel from the panel.

Adjustments – Depth.

Once the weather seal has been set in place, close the door panel and check the depth to ensure it aligns with the car and compresses the rubber seal. If adjustment is required loosen the hinges from the top supports (the gas struts do not need to be removed), apply pressure evenly to the outside of the door where the hinge meets the door until you see the rubber compress onto the frame, and then re-tighten the bolts.

LC76 Emuwing Installation Instructions

Due to the intrusion of the hinge this product is not suitable for vehicles with passengers in the seats adjacent to the Emuwing. The Emuwing is designed as **an addition** to a storage system and should be removed if the seats adjacent to the Emuwing are ever reinstated.

You may also need to bend the cams on the door locks to compress the bottom part of the rubber seal. To do this remove the cam by taking the screw out from the back of the door handle. Put the cam into a vice so that any bend is applied away from the square hole – do not distort or bend this part of the cam. Bend slightly and then retest until the rubber on the panel compresses equally top and bottom.

Thread locking compound – handle/cam screws.

*The small screw holding the handle and cam in place has not had thread locking compound applied to facilitate any bending required. **It is essential this is applied onto these screws to ensure you retain your handles.***

Close the Emuwing and leave the car in the sun for a few hours to activate the glue on the back of the weather seal – leave the wing closed for around 24 hours while the glue on the weather seal sets. The panel needs to get hot to the touch to activate the glue on the weather seal and ensure long term adhesion. A heat gun may assist in colder weather.

If additional help is required, please feel free to give us a call on +613 8592 1926 between the hours of 10am and 4pm AEST – Monday to Friday.

LC76 Emuwing Installation Instructions

Due to the intrusion of the hinge this product is not suitable for vehicles with passengers in the seats adjacent to the Emuwing. The Emuwing is designed as *an addition* to a storage system and should be removed if the seats adjacent to the Emuwing are ever reinstated.

5. Glass supplement.

Please note the following:

Handles have been inserted so you can easily reassemble them after having the glass wing panels tinted. When reassembling, you must use some thread locking compound on the threads to prevent them loosening. Failure to do so may result in the loss of the entire assembly including the handle and lock, this will not be covered under warranty.

We recommend tinting the glass prior to installation, this ensures the weather strip will not deteriorate faster than usual due to UV exposure.

Instructions:

1. Remove handles
2. Tint glass wing panel to match the existing tint on your vehicle.
3. Reassemble handles using thread locking compound on all threads

Prior to installation of the Emuwing kit the handles should be reassembled into the glass panel using a thread locking compound on the large barrel nut, apply enough to ensure this barrel nut will not loosen.

Tighten the barrel nut until the rubbers are compressed ensuring a good seal.

Do not use thread locking compound on the screw holding the cam in place at this stage, this is done later in the installation process.